



Refrigerated Showcases

Models RS-CN-0270, 0370, 0370-S, 0470
Items 39539, 40519, 39540, 47105

Instruction Manual



STOP
DO NOT RETURN
THIS PRODUCT TO THE STORE

For questions or assistance with this product call OMCAN Toll Free: 1 800 465 0234
Customer Service
or
visit the Support section of www.omcan.com

Revised - 01/17/2023

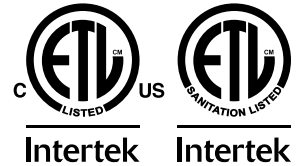

Toll Free: 1-800-465-0234
Fax: 905-607-0234
Email: service@omcan.com
www.omcan.com

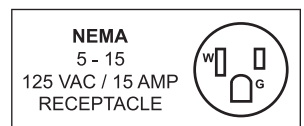

Table of Contents

Model RS-CN-0270 / Model RS-CN-0370
Model RS-CN-0370-S / Model RS-CN-0470

Section	Page
Disclaimer -----	3
General Information -----	4 - 5
Safety and Warranty -----	5 - 7
Technical Specifications -----	7
Operation -----	8
Maintenance -----	9
Troubleshooting -----	10
Parts Breakdown -----	11 - 18
Electrical Schematics -----	19 - 20
Notes -----	21 - 22
Warranty Registration -----	23

Disclaimer

OMCAN IS NOT RESPONSIBLE FOR ANY DAMAGES DUE TO WATER LEAKS. WARRANTY FOR WATER LEAKS IS VOID IF THE AMBIENT ROOM TEMPERATURE EXCEEDS 75°F AND 55% RELATIVE HUMIDITY, AND THE APPLIANCE DRAIN IS NOT CONNECTED DIRECTLY TO A FLOOR DRAIN.

OMCAN N'EST PAS RESPONSABLE DES DOMMAGES DUS AUX FUITES D'EAU. LA GARANTIE POUR LES FUITES D'EAU EST ANNULÉE SI LA TEMPÉRATURE AMBIANTE DE LA PIÈCE DÉPASSE 75°F ET 55% D'HUMIDITÉ RELATIVE, ET SI LE DRAIN DE L'APPAREIL N'EST PAS RACCORDÉ DIRECTEMENT À UN DRAIN DE PLANCHER.

OMCAN NO SE HACE RESPONSABLE DE LOS DAÑOS CAUSADOS POR FUGAS DE AGUA. LA GARANTÍA POR FUGAS DE AGUA QUEDA ANULADA SI LA TEMPERATURA AMBIENTE SUPERA LOS 75°F Y EL 55% DE HUMEDAD RELATIVA, Y EL DESAGÜE DEL APARATO NO ESTÁ CONECTADO DIRECTAMENTE A UN DESAGÜE DE PISO.

General Information

Omcan Manufacturing and Distributing Company Inc., Food Machinery of America, Inc. dba Omcan and Omcan Inc. are not responsible for any harm or injury caused due to any person's improper or negligent use of this equipment. The product shall only be operated by someone over the age of 18, of sound mind, and not under the influence of any drugs or alcohol, who has been trained in the correct operation of this machine, and is wearing authorized, proper safety clothing. Any modification to the machine voids any warranty, and may cause harm to individuals using the machine or in the vicinity of the machine while in operation.

CHECK PACKAGE UPON ARRIVAL

Upon receipt of an Omcan shipment please inspect for external damage. If no damage is evident on the external packaging, open carton to ensure all ordered items are within the box, and there is no concealed damage to the machine. If the package has suffered rough handling, bumps or damage (visible or concealed), please note it on the bill of lading before accepting the delivery and contact Omcan within 24 hours, so we may initiate a claim with the carrier. A detailed report on the extent of the damage caused to the machine must be filled out within three days, from the delivery date shown in the shipping documents. Omcan has no recourse for damaged products that were shipped collect or third party.

Before operating any equipment, always read and familiarize yourself with all operation and safety instructions.

Omcan would like to thank you for purchasing this machine. It's of the utmost importance to save these instructions for future reference. Also save the original box and packaging for shipping the equipment if servicing or returning of the machine is required.

Omcan Fabrication et distribution Compañie Limité et Food Machinery d'Amérique, dba Omcan et Omcan Inc. ne sont pas responsables de tout dommage ou blessure causé du fait que toute personne ait utilisé cet équipement de façon irrégulière. Le produit ne doit être exploité que par quelqu'un de plus de 18 ans, saine d'esprit, et pas sous l'influence d'une drogue ou d'alcool, qui a été formé pour utiliser cette machine correctement, et est vêtu de vêtements de sécurité approprié. Toute modification de la machine annule toute garantie, et peut causer un préjudice à des personnes utilisant la machine ou des personnes à proximité de la machine pendant son fonctionnement.

VÉRIFIEZ LE COLIS DÈS RÉCEPTION

Dès réception d'une expédition d'Omcan veuillez inspecter pour dommages externes. Si aucun dommage n'est visible sur l'emballage externe, ouvrez le carton afin de s'assurer que tous les éléments commandés sont dans la boîte, et il n'y a aucun dommage dissimulé à la machine. Si le colis n'a subi aucune mauvaises manipulations, de bosses ou de dommages (visible ou cachée), notez-le sur le bond de livraison avant d'accepter la livraison et contactez Omcan dans les 24 heures qui suivent, pour que nous puissions engager une réclamation auprès du transporteur. Un rapport détaillé sur l'étendue des dommages causés à la machine doit être rempli dans un délai de trois jours, à compter de la date de livraison indiquée dans les documents d'expédition. Omcan n'a aucun droit de recours pour les produits endommagés qui ont été expédiés ou cueilli par un tiers transporteur.



General Information

Avant d'utiliser n'importe quel équipement, toujours lire et vous familiariser avec toutes les opérations et les consignes de sécurité.

Omcan voudrais vous remercier d'avoir choisi cette machine. Il est primordial de conserver ces instructions pour une référence ultérieure. Également conservez la boîte originale et l'emballage pour l'expédition de l'équipement si l'entretien ou le retour de la machine est nécessaire.

Omcan Empresa De Fabricacion Y Distribucion Inc. Y Maquinaria De Alimentos De America, Inc. dba Omcan y Omcan Inc. no son responsables de ningun daño o perjuicio causado por cualquier persona inadecuada o el uso descuidado de este equipo. El producto solo podra ser operado por una persona mayor de 18 años, en su sano juicio y no bajo alguna influencia de droga o alcohol, y que este ha sido entrenado en el correcto funcionamiento de esta máquina, y ésta usando ropa apropiada y autorizada. Cualquier modificación a la máquina anula la garantía y puede causar daños a las personas usando la máquina mientras esta en el funcionamiento.

REVISE EL PAQUETE A SU LLEGADA

Tras la recepcion de un envio Omcan favor inspeccionar daños externos. Si no hay daños evidentes en el empaque exterior, Habra el carton para asegurarse que todos los articulos solicitados estén dentro de la caja y no encuentre daños ocultos en la máquina. Si el paquete ha sufrido un manejo de poco cuidado, golpes o daños (visible o oculto) por favor anote en la factura antes de aceptar la entrega y contacte Omcan dentro de las 24 horas, de modo que podamos iniciar una reclamación con la compañía. Un informe detallado sobre los daños causados a la máquina debe ser llenado en el plazo de tres días, desde la fecha de entrega que se muestra en los documentos de envío. Omcan no tiene ningun recurso por productos dañados que se enviaron a recoger por terceros.

Antes de utilizar cualquier equipo, siempre lea y familiarizarse con todas las instrucciones de funcionamiento y seguridad.

Omcan le gustaría darle las gracias por la compra de esta máquina. Es de la mayor importancia para salvar estas instrucciones para futuras consultas. Además, guarda la caja original y el embalaje para el envío del equipo si servicio técnico o devolución de la máquina que se requiere.

Safety and Warranty

HANDLING AND INSTALLATION

Handle with care Unplug from the wall socket before moving. Never tilt the refrigerator over 45 degrees during handling.	Storage Always store the refrigerator in a dry place.
--	---

Safety and Warranty

<p>Sufficient space To allow for proper air circulation and increased refrigeration capabilities, the refrigerator must have at least 4"/10cm of space between wall/ceiling and the machine.</p>	<p>Proper ventilation Always place the refrigerator in an area with good ventilation. For first time use, set in location and wait at least 2 hours before plugging into wall socket.</p>
<p>Away from heat source Never place the refrigerator near any type of heat source or in direct sunlight, as it reduces refrigeration capabilities.</p>	<p>No heavy load Never put heavy items on top of the refrigerator.</p>
<p>No altercations/tampering Never tamper with or make changes to the refrigerator. Changes and add-ons should not be installed to the inside or outside of the refrigerator.</p>	<p>Stable location Unpack and place the refrigerator on flat, solid ground.</p>

PREPARATION AND POWER SUPPLY

<p>Exclusive power outlet Power supply should be 110-120V, single phase AC with exclusive single phase three pin outlet (125V/15A). The power outlet must be in close proximity to the ground.</p>	<p>No shared power outlets Refrigerator cable should never share the power outlet with any other appliance, as cable will overheat and may result in a fire.</p>
<p>Protect cables Extra caution should be used when handling cables, as broken or damaged cables can cause sparking and may result in a fire.</p>	<p>No water flushing Never flush the refrigerator surface. This can cause leakage, which may result in electrical damage or fire.</p>
<p>Never store flammables and explosives No explosives or flammables should be stored in, or in proximity to, the refrigerator, such as gasoline, alcohol, and adhesives.</p>	<p>No spray Never spray flammables such as paint or coating near the refrigerator. This may cause fire or malfunction.</p>
<p>After power outage After a power outage or the unplugging of the refrigerator, wait at least 5 minutes before plugging it back in.</p>	<p>No medicine Medicine should not be stored inside of the refrigerator.</p>

RESIDENTIAL USERS: Vendor assumes no liability for parts or labor coverage for component failure or other damages resulting from installation in non-commercial or residential applications. The right is reserved to deny shipment for residential usage; if this occurs, you will be notified as soon as possible.

1 YEAR PARTS AND LABOUR WARRANTY

Within the warranty period, contact Omcan Inc. at 1-800-465-0234 to schedule an Omcan authorized service technician to repair the equipment locally.



Safety and Warranty

Unauthorized maintenance will void the warranty. Warranty covers electrical and part failures not improper use.

Please see <https://omcan.com/disclaimer> for complete info.

WARNING:

The packaging components are classified as normal solid urban waste and can therefore be disposed of without difficulty.

In any case, for suitable recycling, we suggest disposing of the products separately (differentiated waste) according to the current norms.

DO NOT DISCARD ANY PACKAGING MATERIALS IN THE ENVIRONMENT!

Technical Specifications

Model	RS-CN-0270	RS-CN-0370	RS-CN-0370-S	RS-CN-0470
Capacity	270 L / 9.5 cu.ft.	370 L / 13 cu.ft.		500 L / 17.7 cu.ft.
Temperature Range	2° - 8°C / 35.6° - 46.4°F			
Max Ambient Temp Rating	24°C / 75°F			
Refrigerant	R290			
Electrical	110-120V / 60Hz / 1			
Top Rack Size	31.7" x 13.7" 805 x 348mm	43.5" x 14" 1105 x 356mm		55.2" x 12.2" 1401 x 311mm
Bottom Rack Size	31.7" x 16" 805 x 406mm	43.5" x 16" 1105 x 406mm		55.2" x 14.6" 1401 x 371mm
Dimensions	36" x 26.6" x 50.2" 914 x 676 x 1276mm	47.8" x 26.6" x 50" 1214 x 676 x 1270mm		59.6" x 26.6" x 48" 1515 x 675 x 1220mm
Packaging Dimensions	38" x 28.5" x 51.6" 965 x 724 x 1311mm	49.8" x 31.3" x 51.6" 1265 x 795 x 1311mm		63" x 29.3" x 50" 1600 x 743 x 1270mm
Weight	360.5 lbs. / 163.5 kgs.			401.2 lbs. / 182 kgs.
Packaging Weight	379.2 lbs. / 172 kgs.			507.1 lbs. / 230 kgs.
Item Number	39539	40519	39540	47105

Operation

BEFORE USE

- Plug refrigerator into the 110-120V exclusive socket.
- After the refrigerator is running, confirm that air suction/filtration is in working order and that it is sufficiently cold. After checking to make sure the refrigerator is working properly, it may be used.

DIGITAL TEMPERATURE CONTROLLER

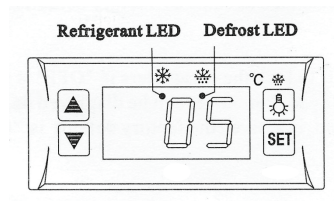

FEATURES OF FUNCTION

- Small, integrated digital controller, which is applicable to the compressor of 1 Hp. Located behind the front grill.
- Main functions are: Temperature Display/Temperature Control/Manual-Automatic /Light Control/Value Storing/Self-Testing/Parameter Locking.

FRONT PANEL OPERATION

1. Set temperature: Press **SET** button; set temperature will be displayed. Press **▲** or **▼** button to modify and store the displayed value. Press **SET** button to exit the adjustment and display the cold-room temperature.
2. If no button is pressed within 10 seconds, the cold-room temperature will be displayed.
3. Lighting: Press **☞** button to activate light in refrigerator; press again to turn off. Manual start/stop defrost: Press **☞** button and hold for 6 seconds to either defrost or to stop defrost.
4. Refrigeration LED: During refrigeration, the LED is on. When the cold room temperature is constant, the LED is off. During delay start, the LED flashes.
5. Defrost LED: During defrosting, the LED is on. When it stops defrosting, the LED is off. During the delay of defrost, the LED flashed.

Maintenance

1. Cabinet Cleaning:
 - a. The product should be maintained and cleaned periodically with power supply disconnected. In cleaning, please use mild-rinsing water or non-corrosive products. Do not wash directly with water faucet.
 - b. Clean outside of unit using a soft cloth with neutral detergent, and dry with a separate soft cloth.
 - c. Clean inside racks by removing them from the unit and clean with water.
2. When shutting down unit for a long period of time, take out all food and unplug wall socket. Clean inside and outside thoroughly, and keep door open to sufficiently dry.
3. As glass breaks easily, keep far away from children.
4. Replacement of Lamp in Light Box: If the LED lamp is damaged, it must be replaced by Omcan or its service agent.
5. Frequently observe the operation of the product. In case of any abnormal noise or smell, cut off the power supply immediately and call professionals. Do not restart the product before source of trouble is found.
6. We will not be responsible for any accidents acquired through failure to follow previous notices.

CAUTIONS

- Minimizing time the time and frequency that the door is open will maintain temperature.
- Never block the air outlet and suction to keep the air circulation and refrigeration capability constant.
- Do not overfill refrigerator with food, as it will influence the cooling effect. If needed, adjust the rack height for proper food storage.
- Cool down hot food to room temperature before placing inside the refrigerator.
- During power interruptions, reduce opening times and maintain cool temperature in refrigerator.
- To avoid scalding, never touch the compressor.
- If the supply cord is damaged, it must be replaced by the manufacturer, its service agent, or similarly qualified persons in order to avoid hazard.
- This appliance is not intended for use by persons (including children) with reduced physical, sensory or mental capabilities, or lack of experience and knowledge, unless they have been given supervision or instruction concerning use of the appliance by a person responsible for their safety.
- Children should be supervised to ensure that they do not play with the appliance.

WARNING: Keep ventilation openings clear of obstructions.

WARNING: Do not use mechanical devices of other means to accelerate the defrosting process, other than those recommended by the manufacturer.

WARNING: Do not damage the refrigerant circuit.

WARNING: Do not use electrical appliances inside the food storage compartments of the appliance, unless they are of the type recommended by the manufacturer.

Troubleshooting

Trouble	Cause and Remedy
No Refrigeration.	Is the plug fitting in the socket?
	Is the fuse broken?
	Is there no power?
Unsatisfactory Refrigeration.	Is it under sunshine? Is there any heat source nearby?
	Is the surrounding ventilation poor?
	Is the door closed? Is the door open for a long period of time?
	Is the door seal strip deformed or damaged?
	Is there too much food?
	Does food block the air suction or outlet?
	Regulate the temperature controller.
Noisy.	The refrigerator is not level.
	The refrigerator contacts the wall or other matter.
	There is loose part in refrigerator.
Contact Omcan for help if simple troubleshooting does not solve the problems.	

NOTE

Following occurrences are not problems:

- The murmur of water is heard when the refrigerator is working. It is a normal occurrence as the coolant is circulating in the system.
- When the weather is damp, condensation might be found on the outside of the refrigerator. It is caused by high humidity. Simply use cloth to wipe it off.

Parts Breakdown

Model RS-CN-0270 39539

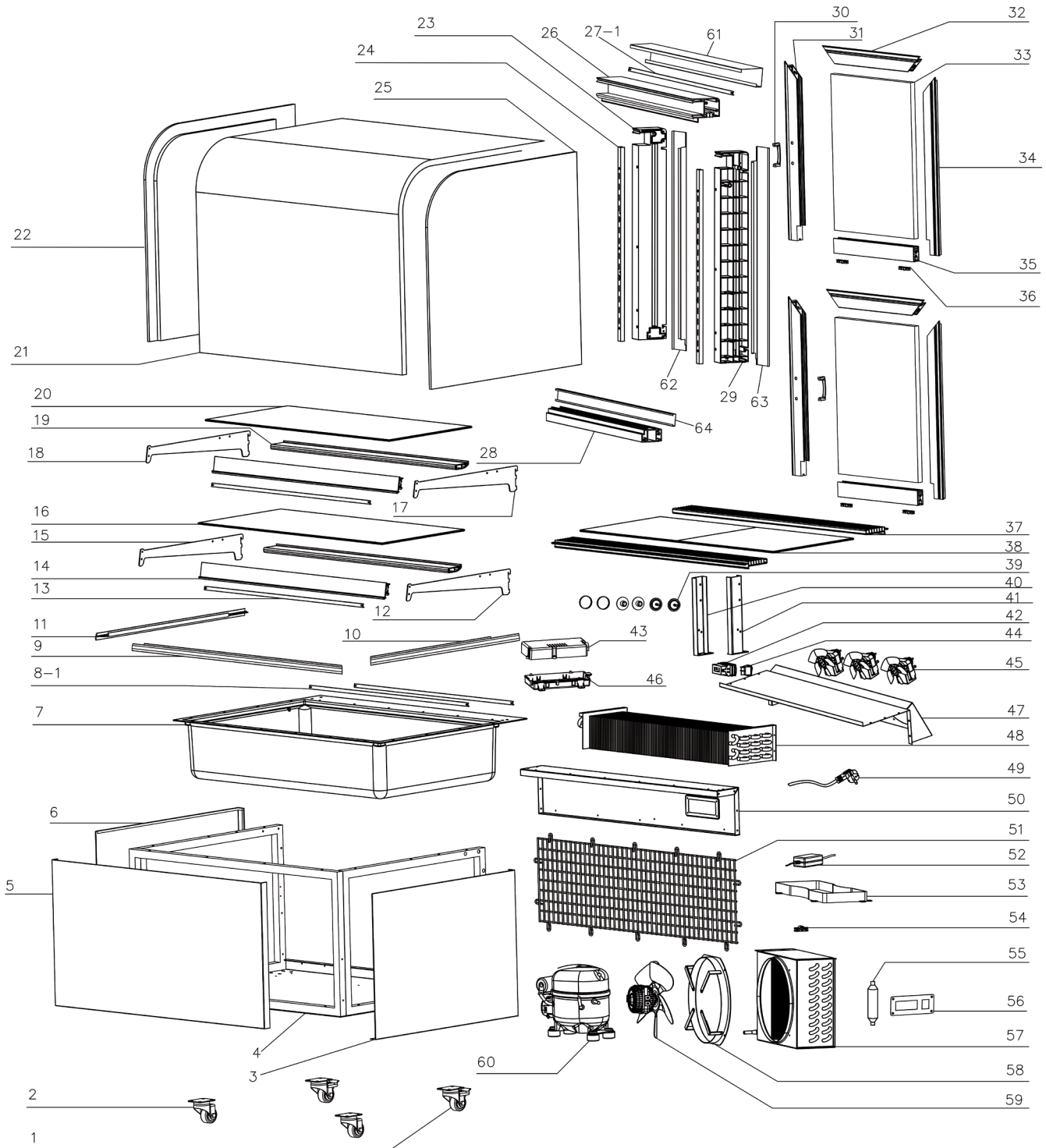

Parts Breakdown

Model RS-CN-0270 39539

Item No.	Description	Position	Item No.	Description	Position	Item No.	Description	Position
71042	Rear Swivel Caster with Brake for 39539	1	71164	Left Pole Cover for 39539	23	71081	Evaporator Motor for 39539	45
79763	Swivel Front Castor without Brake for 39539	2	71153	Shelf Holder for 39539	24	71082	Thermostat Base for 39539	46
68165	Base for 39539	3	71062	Right Side Glass for 39539	25	68197	Evaporator Cover for 39539	47
68225	Right Cover for 39539	4	64746	Top Frame for 39539	26	71084	Evaporator for 39539	48
AG707	Front Cover for 39539	5	68204	Top LED for 39539	27-1	68198	Power Cord for 39539	49
68226	Left Cover for 39539	6	71064	Bottom Frame for 39539	28	71086	Rear Frame for 39539	50
71046	Evaporator Insulation for 39539	7	71065	Right Pole for 39539	29	71087	Back Grill for 39539	51
68168	Bottom LED for 39539	8-1	71110	Door Handle for 39539	30	AG710	4 LED Driver for 39539	52
71047	Front Glass Fixer for 39539	9	AF488	Left Doorframe for 39539	31	71089	Water Tray for 39539	53
71048	Right Glass Fixer for 39539	10	71068	Top Upper Door Frame for 39539	32	71133	Power Cord Fixer for 39539	54
71049	Left Glass Fixer for 39539	11	71069	Door Glass for 39539	33	71083	Dryer Filter for 39539	55
41966	Shelf Bracket-Bottom Right for 39539	12	71113	Right Door Frame for 39539	34	77434	Control Panel for 39539	56
68176	Middle LED for 39539	13-1	71071	Bottom Door Frame for 39539	35	71135	Condenser for 39539	57
AF486	Metal Price Tags for 39539	14	71114	Door Glide Wheel for 39539	36	71136	Fan Bracket for 39539	58
71152	Bottom Shelf Left Bracket for 39539	15	71073	Air In/Outlet for 39539	37	71137	Condenser Motor for 39539	59
AG708	Bottom Glass Shelf for 39539	16	71074	Bottom Black Glass Frame for 39539	38	68199	Compressor for 39539	60
71051	Right Top Shelf Holder for 39539	17	71121	Screw Cover for 39539	39	AF490	Top Back Frame for 39539	61
41612	Shelf Bracket-Top Left for 39539	18	71171	Left Pole Fixer for 39539	40	AF491	Left Back Frame for 39539	62
AF487	Metal Shelf Support for 39539	19	71077	Right Pole Fixer for 39539	41	AF492	Right Back Frame for 39539	63
AG709	Top Glass Shelf for 39539	20	71123	Digital Control for 39539	42	AF493	Bottom Back Frame for 39539	64
64745	Arc Glass for 39539	21	71079	Thermostat Lid for 39539	43			
71103	Left Side Glass for 39539	22	71080	Switch for 39539	44			

Parts Breakdown

Model RS-CN-0370 40519

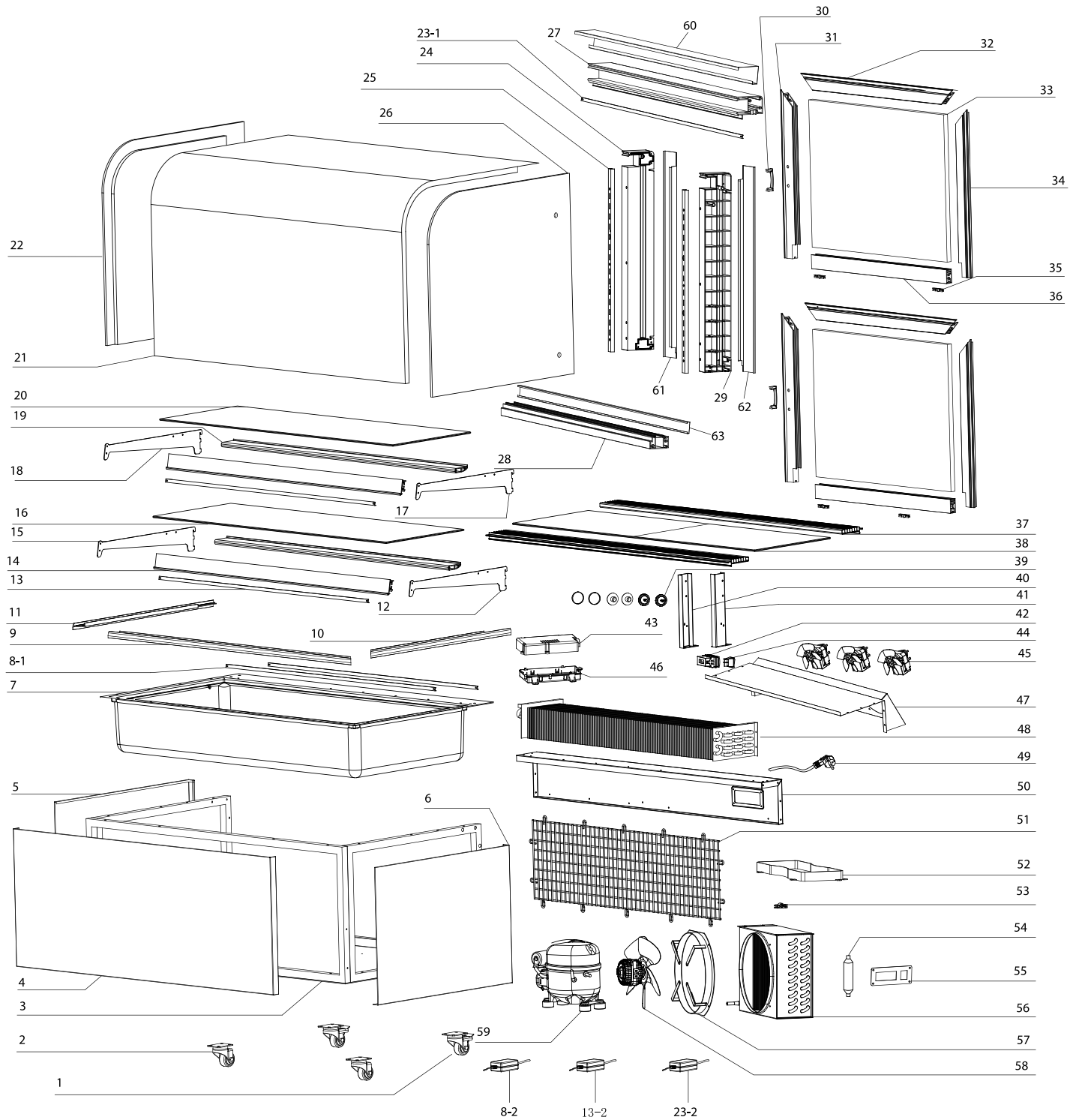

Parts Breakdown

Model RS-CN-0370 40519

Item No.	Description	Position	Item No.	Description	Position	Item No.	Description	Position
71042	Rear Swivel Caster with Brake for 40519	1	71103	Left Side Glass for 40519	22	71079	Thermostat Lid for 40519	43
79763	Swivel Front Caster without Brake for 40519	2	AF496	Top LED for 40519	23-1	71080	Switch for 40519	44
68206	Base for 40519	3	64751	#2 LED Transformer for 40519	23-2	71081	Evaporator Motor for 40519	45
68225	Right Cover for 40519	4	71164	Left Pole Cover for 40519	24	71082	Thermostat Base for 40519	46
AF494	Front Cover for 40519	5	71153	Shelf Holder for 40519	25	71126	Evaporator Cover for 40519	47
68226	Left Cover for 40519	6	71062	Right Side Glass for 40519	26	71127	Evaporator for 40519	48
71094	Evaporator Insulation for 40519	7	71104	Upper Front Frame for 40519	27	68198	Power Cord for 40519	49
68208	Bottom LED for 40519	8-1	71165	Bottom Frame for 40519	28	71129	Rear Frame for 40519	50
64750	#4 LED Transformer for 40519	8-2, 13-2	71065	Right Pole for 40519	29	71130	Back Grill for 40519	51
AF495	Front Glass Fixer for 40519	9	71110	Door Handle for 40519	30	71089	Water Tray for 40519	52
68272	Left Glass Fixer for 40519	10	AF488	Left Doorframe for 40519	31	71133	Power Cord Fixer for 40519	53
68271	Right Glass Fixer for 40519	11	71111	Upper Door Frame for 40519	32	71083	Dryer Filter for 40519	54
68172	Right Bottom Shelf Holder for 40519	12	64880	Right Side Glass for 40519	33	77434	Control Panel for 40519	55
71149	LED Lighter for 40519	13-1	71113	Right Door Frame for 40519	34	71135	Condenser for 40519	56
71150	Price Tags for 40519	14	71114	Door Glide Wheel for 40519	35	71136	Fan Bracket for 40519	57
68211	Left Bottom Shelf Holder for 40519	15	71167	Bottom Door Frame for 40519	36	71137	Condenser Motor for 40519	58
71100	Bottom Glass Shelf for 40519	16	71119	Inlet and Outlet for 40519	37	68199	Compressor for 40519	59
68175	Right Top Shelf Holder for 40519	17	AD842	Bottom Glass for 40519	38	AF497	Top Back Frame for 40519	60
68177	Left Top Shelf Holder for 40519	18	71121	Screw Cover for 40519	39	AF491	Left Back Frame for 40519	61
64749	Metal Shelf Support for 40519	19	71171	Left Pole Fixer for 40519	40	AF492	Right Back Frame for 40519	62
71105	Top Glass Shelf for 40519	20	71077	Right Pole Fixer for 40519	41	AF498	Bottom Back Frame for 40519	63
71102	Arc Front Glass for 40519	21	71123	Digital Control for 40519	42			

Parts Breakdown

Model RS-CN-0370-S 39540

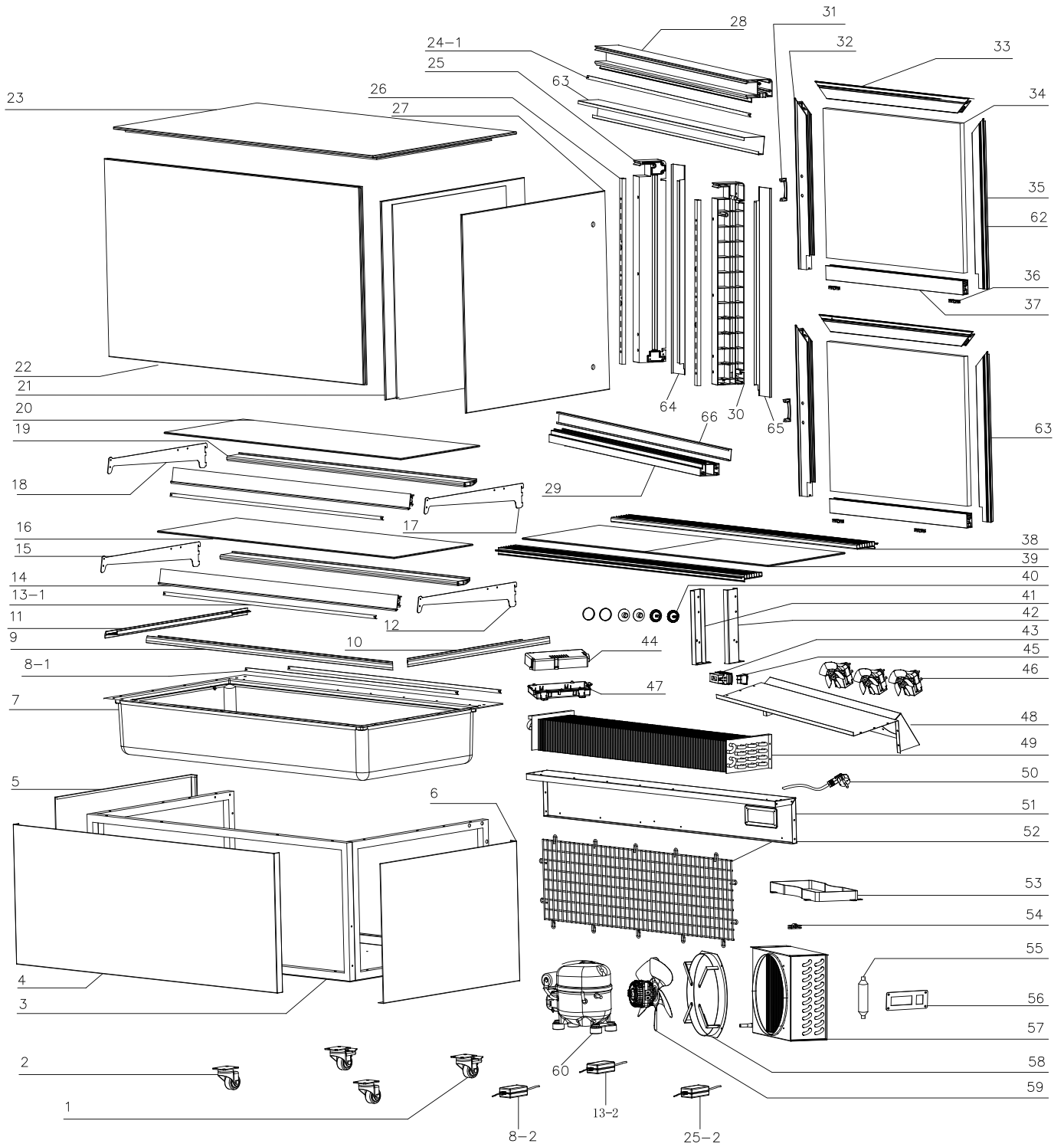

Parts Breakdown

Model RS-CN-0370-S 39540

Item No.	Description	Position	Item No.	Description	Position	Item No.	Description	Position
71042	Rear Swivel Caster with Brake for 39540	1	AL691	Top Glass for 39540	23	68196	Switch for 39540	45
79763	Swivel Front Castor without Brake for 39540	2	AF496	Top LED for 39540	24-1	71081	Evaporator Motor for 39540	46
68206	Base for 39540	3	AK201	6 LED Driver for 39540	24-2	71082	Thermostat Base for 39540	47
AF494	Front Cover for 39540	4	71164	Left Pole Cover for 39540	25	71126	Evaporator Cover for 39540	48
68225	Right Cover for 39540	5	71153	Shelf Holder for 39540	26	71127	Evaporator for 39540	49
68226	Left Cover for 39540	6	AL692	Right Glass for 39540	27	68198	Power Cord for 39540	50
71094	Evaporator Insulation for 39540	7	71104	Upper Front Frame for 39540	28	71129	Rear Frame for 39540	51
68208	Bottom LED for 39540	8-1	71165	Bottom Frame for 39540	29	71130	Back Grill for 39540	52
AK203	4 LED Driver for 39540	8-2, 13-2	71065	Right Pole for 39540	30	71089	Water Tray for 39540	53
AF495	Front Glass Fixer for 39540	9	71110	Door Handle for 39540	31	71133	Power Cord Fixer for 39540	54
68272	Left Glass Fixer for 39540	10	AF488	Left Doorframe for 39540	32	71083	Dryer Filter for 39540	55
68271	Right Glass Fixer for 39540	11	71111	Upper Door Frame for 39540	33	AL693	Control Panel for 39540	56
41966	Shelf Bracket-Bottom Right for 39540	12	71112	Glass Door for 39540	34	71135	Condenser for 39540	57
71149	LED Lighter for 39540	13-1	71113	Right Door Frame for 39540	35	71136	Fan Bracket for 39540	58
71150	Price Tags for 39540	14	71114	Door Glide Wheel for 39540	36	71137	Condenser Motor for 39540	59
71152	Bottom Shelf Left Bracket for 39540	15	71167	Bottom Door Frame for 39540	37	68199	Compressor for 39540	60
71100	Bottom Glass Shelf for 39540	16	AK204	Air In/Outlet for 39540	38	AL694	Left Door for 39540	61
71051	Right Top Shelf Holder for 39540	17	AD842	Bottom Glass for 39540	39	AL695	Right Door for 39540	62
41612	Shelf Bracket-Top Left for 39540	18	71121	Screw Cover for 39540	40	AF497	Top Back Frame for 39540	63
64749	Metal Shelf Support for 39540	19	71171	Left Pole Fixer for 39540	41	AL696	Left Back Frame (Stainless Steel) for 39540	64
71105	Top Glass Shelf for 39540	20	71077	Right Pole Fixer for 39540	42	AL697	Right Back Frame (Stainless Steel) for 39540	65
AL689	Left Glass for 39540	21	71123	Digital Control for 39540	43	AF498	Bottom Back Frame for 39540	66
AL690	Front Glass for 39540	22	71079	Thermostat Lid for 39540	44			

Parts Breakdown

Model RS-CN-0470 47105

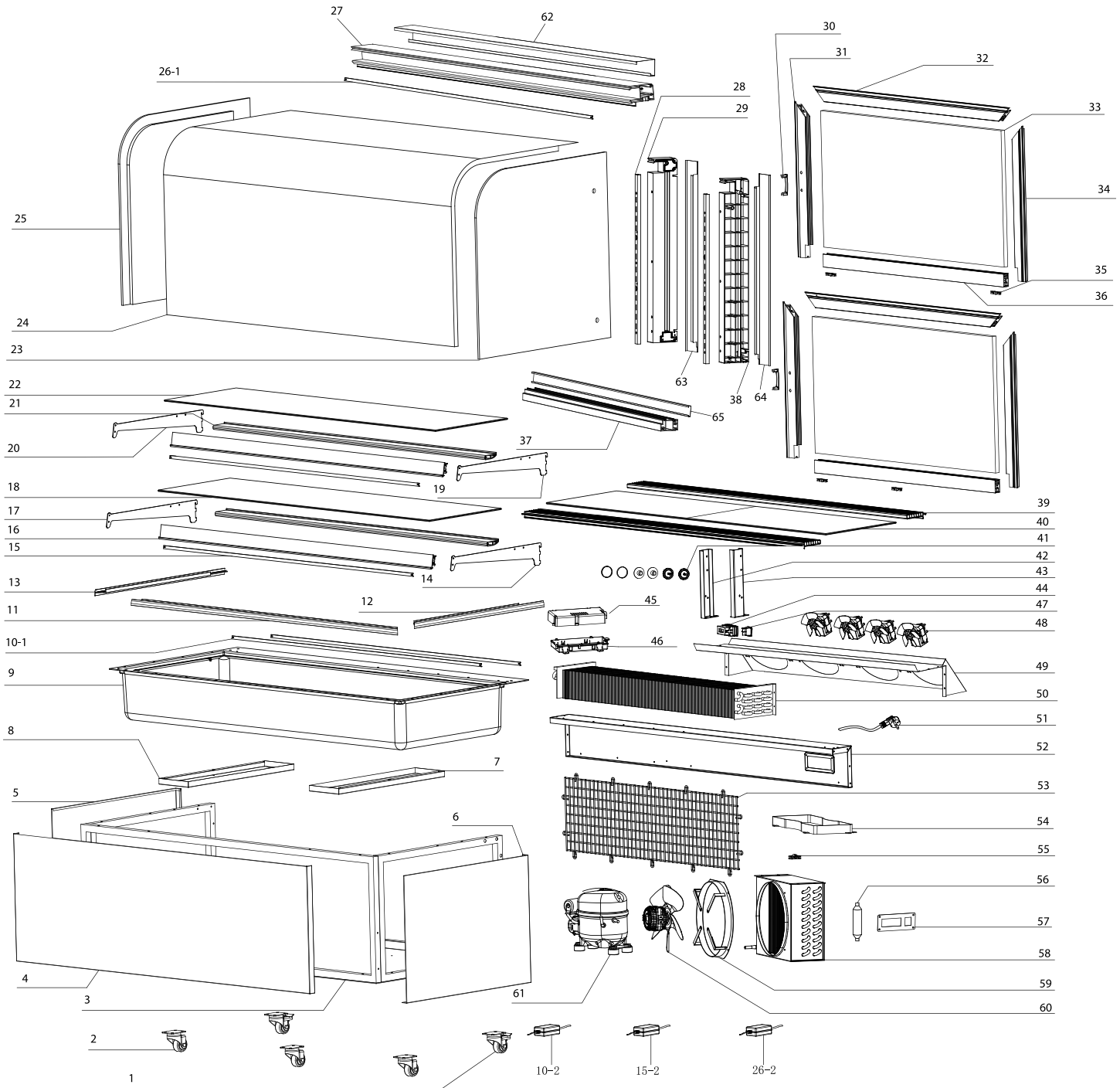

Parts Breakdown

Model RS-CN-0470 47105

Item No.	Description	Position	Item No.	Description	Position	Item No.	Description	Position
71042	Rear Swivel Caster with Brake for 47105	1	AG490	Top Glass Shelf for 47105	22	71123	Digital Control for 47105	44
79763	Swivel Front Castor without Brake for 47105	2	71103	Left Side Glass for 47105	23, 25	71079	Thermostat Lid for 47105	45
68228	Base for 47105	3	AG491	Arc Glass for 47105	24	71082	Thermostat Base for 47105	46
AG485	Front Cover for 47105	4	68242	Top LED for 47105	26-1	68196	Switch for 47105	47
68225	Right Cover for 47105	5	AG588	6 LED Driver for 47105	26-2	71081	Evaporator Motor for 47105	48
68226	Left Cover for 47105	6	AG492	Top Frame for 47105	27	68255	Evaporator Cover for 47105	49
68230	Left Blister Barrel Fixing Plate for 47105	7, 8	71153	Shelf Holder for 47105	28	71127	Evaporator for 47105	50
68232	Evaporator Insulation for 47105	9	71164	Left Pole Cover for 47105	29	AF489	Power Cord for 47105	51
68208	Bottom LED for 47105	10-1	71110	Door Handle for 47105	30	68249	Rear Frame for 47105	52
68222	#4 LED Driver for 47105	10-2	AF488	Left Doorframe for 47105	31	68250	Back Grill for 47105	53
AG486	Front Glass Fixer for 47105	11	AF514	Top Door Frame for 47105	32	71089	Water Tray for 47105	54
68272	Left Glass Fixer for 47105	12	68244	Door Glass for 47105	33	71133	Power Cord Fixer for 47105	55
68271	Right Glass Fixer for 47105	13	71113	Right Door Frame for 47105	34	71083	Dryer Filter for 47105	56
68172	Right Bottom Shelf Holder for 47105	14	71114	Door Glide Wheel for 47105	35	77434	Control Panel for 47105	57
68234	Middle LED for 47105	15-1	68245	Bottom Door Frame for 47105	36	71135	Condenser for 47105	58
68235	#2 LED Driver for 47105	15-2	AG494	Bottom Frame for 47105	37	71136	Fan Bracket for 47105	59
AG487	Metal Price Tags for 47105	16	71065	Right Pole for 47105	38	71137	Condenser Motor for 47105	60
68211	Left Bottom Shelf Holder for 47105	17	68247	Air In/Outlet for 47105	39	68199	Compressor for 47105	61
AG488	Bottom Glass Shelf for 47105	18	AF516	Bottom Black Glass Frame for 47105	40	AG495	Top Back Frame for 47105	62
68175	Right Top Shelf Holder for 47105	19	71121	Screw Cover for 47105	41	AF491	Left Back Frame for 47105	63
68177	Left Top Shelf Holder for 47105	20	71171	Left Pole Fixer for 47105	42	AF492	Right Back Frame for 47105	64
AG489	Metal Shelf Support for 47105	21	71077	Right Pole Fixer for 47105	43	AG496	Bottom Back Frame for 47105	65

Electrical Schematics

Model RS-CN-0270 39539

Model RS-CN-0370 40519

Model RS-CN-0370-S 39540

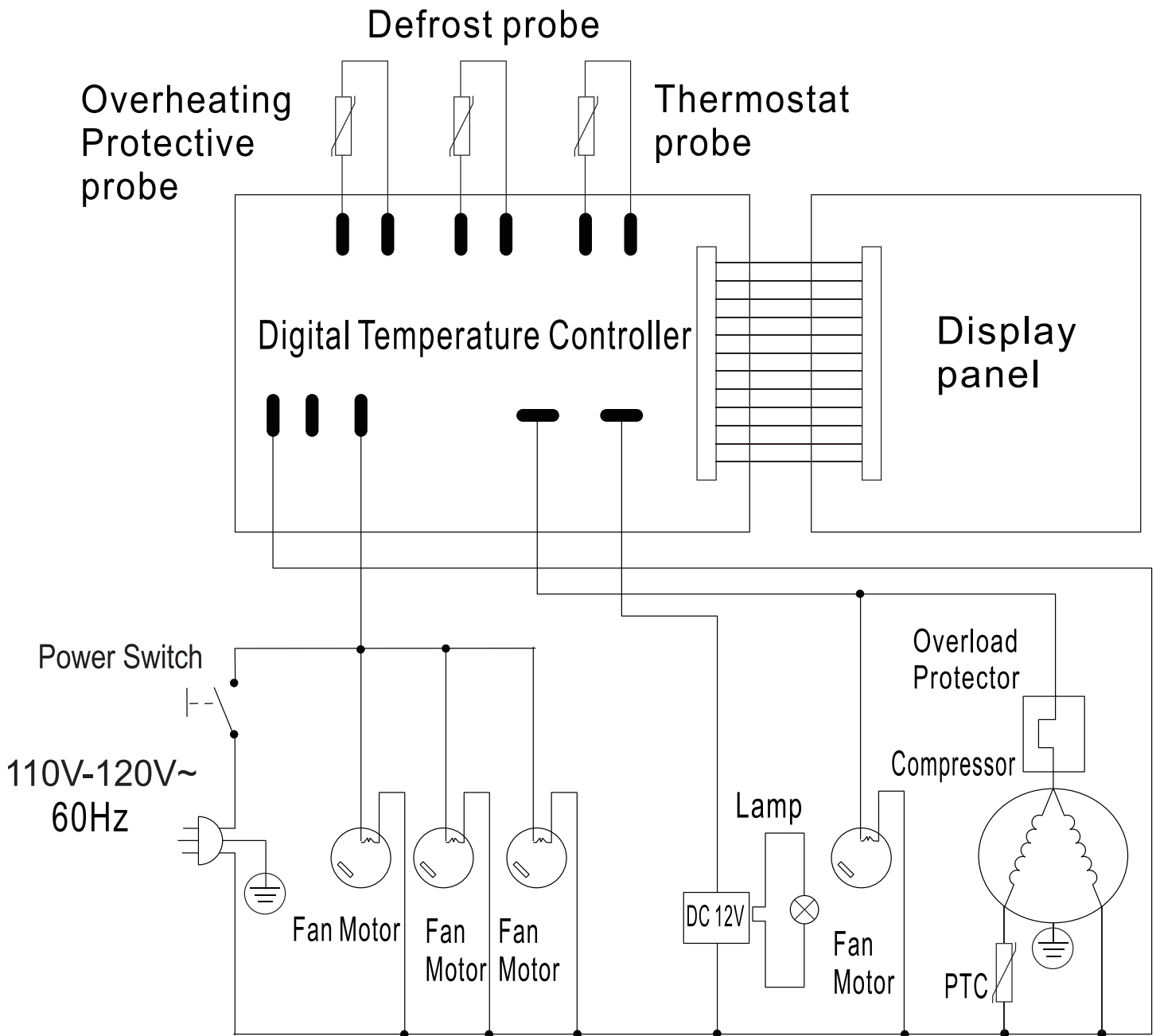

Electrical Schematics

Model RS-CN-0470 47105

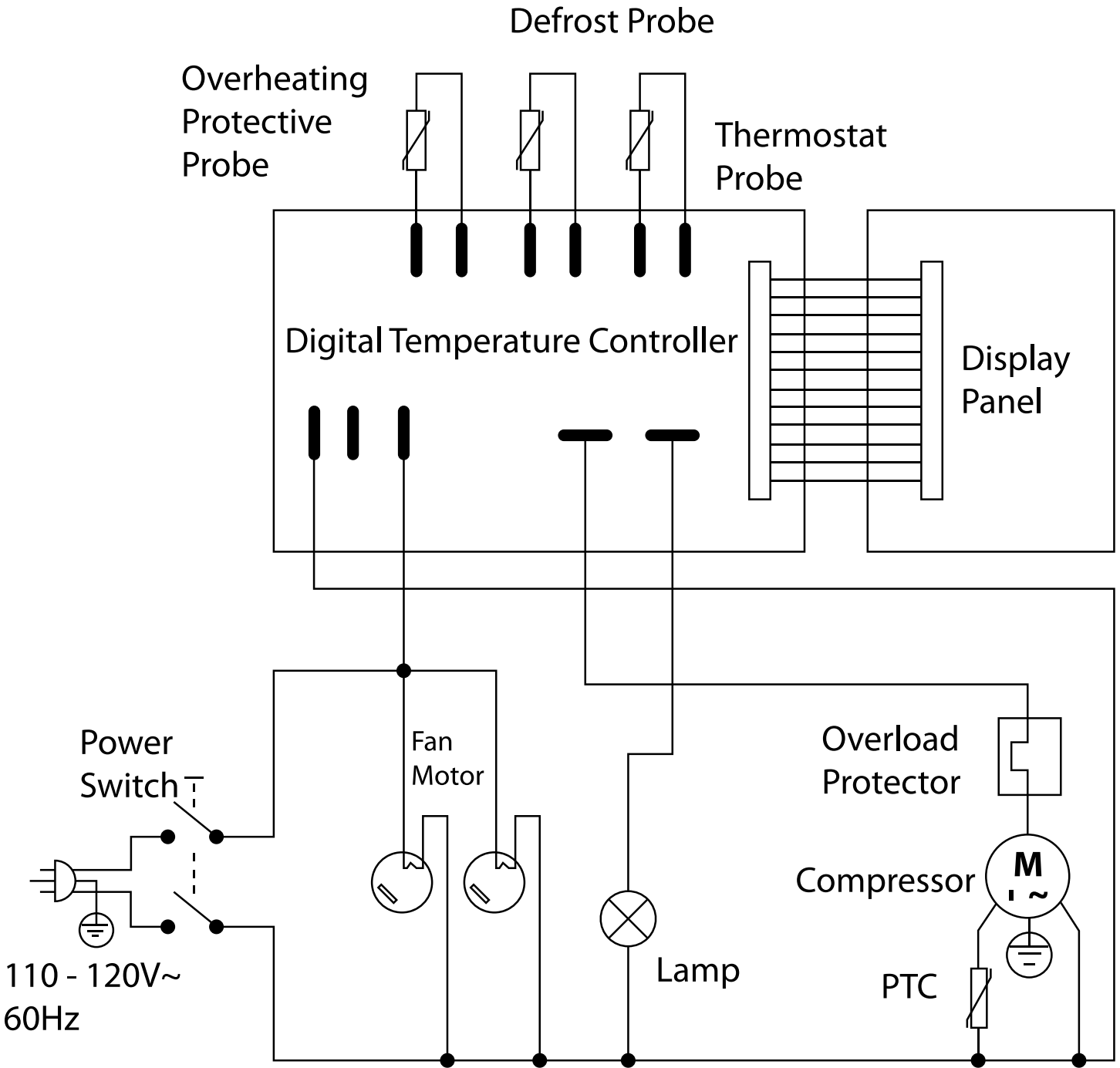



Warranty Registration

Thank you for purchasing an Omcan product. To register your warranty for this product, complete the information below, tear off the card at the perforation and then send to the address specified below. You can also register online by visiting:

Merci d'avoir acheté un produit Omcan. Pour enregistrer votre garantie pour ce produit, complétez les informations ci-dessous, détachez la carte au niveau de la perforation, puis l'envoyer à l'adresse spécifiée ci-dessous. Vous pouvez également vous inscrire en ligne en visitant:

Gracias por comprar un producto Omcan usted. Para registrar su garantía para este producto, complete la información a continuación, cortar la tarjeta en la perforación y luego enviarlo a la dirección indicada a continuación. También puede registrarse en línea en:

<https://omcan.com/warranty-registration/>

For mailing in Canada

Pour postale au Canada

Por correo en Canadá

OMCAN

PRODUCT WARRANTY REGISTRATION

3115 Pepper Mill Court,

Mississauga, Ontario

Canada, L5L 4X5

For mailing in the US

Pour diffusion aux États-Unis

Por correo en los EE.UU.

OMCAN

PRODUCT WARRANTY REGISTRATION

4450 Witmer Industrial Estates, Unit 4,

Niagara Falls, New York

USA, 14305

or email to: service@omcan.com



Purchaser's Information

Name: _____

Address: _____

City: _____ Province or State: _____ Postal or Zip: _____

Country: _____

Dealer from which Purchased: _____

Dealer City: _____ Dealer Province or State: _____

Invoice: _____

Model Name: _____ Model Number: _____

Machine Description: _____

Date of Purchase (MM/DD/YYYY): _____

Would you like to extend the warranty? Yes No

Company Name: _____

Telephone: _____

Email Address: _____

Type of Company:

Restaurant Bakery Deli

Butcher Supermarket Caterer

Institution (specify): _____

Other (specify): _____

Serial Number: _____

Date of Installation (MM/DD/YYYY): _____

Thank you for choosing Omcan | Merci d'avoir choisi Omcan | Gracias por elegir Omcan



Since 1951 Omcan has grown to become a leading distributor of equipment and supplies to the North American food service industry. Our success over these many years can be attributed to our commitment to strengthen and develop new and existing relationships with our valued customers and manufacturers. Today with partners in North America, Europe, Asia and South America, we continually work to improve and grow the company. We strive to offer customers exceptional value through our qualified local sales and service representatives who provide convenient access to over 6,500 globally sourced products.

Depuis 1951 Omcan a grandi pour devenir un des “leaders” de la distribution des équipements et matériel pour l’industrie des services alimentaires en Amérique du Nord. Notre succès au cours de ces nombreuses années peut être attribué à notre engagement à renforcer et à développer de nouvelles et existantes relations avec nos clients et les fabricants de valeur. Aujourd’hui avec des partenaires en Amérique du Nord, Europe, Asie et Amérique du Sud, nous travaillons continuellement à améliorer et développer l’entreprise. Nous nous efforçons d’offrir à nos clients une valeur exceptionnelle grâce à nos ventes locales qualifiées et des représentants de service qui offrent un accès facile à plus de 6500 produits provenant du monde entier.

Desde 1951 Omcan ha crecido hasta convertirse en un líder en la distribución de equipos y suministros de alimentos en América del Norte industria de servicios. Nuestro éxito en estos años se puede atribuir a nuestro compromiso de fortalecer y desarrollar nuevas relaciones existentes con nuestros valiosos clientes y fabricantes. Hoy con socios de América del Norte, Europa, Asia y América del Sur, que trabajan continuamente para mejorar y crecer la empresa. Nos esforzamos por ofrecer a nuestros clientes valor excepcional a través de nuestro local de ventas y representantes de los servicios que proporcionan un fácil acceso a más de 6,500 productos con origen a nivel mundial.

